

---

## DATA SHEET

---

### LIC03 LINET NETWORK CONTROLLER

#### CONTROLLER FEATURES:

- SINGLE 24V DC SUPPLY
- FULLY STAND-ALONE OPERATION
- FULL DUPLEX DATA RATE OF 200\*80 BITS/S
- TIME DIVISION NETWORK PROTOCOL (CONSTANT DATA DELAYS)

#### EXTERNAL INTERFACES:

- LCD/SOFTKEY INTERFACE OPTION
- RS232 OR RS485 SERIAL INTERFACE
- ETHERNET INTERFACE

#### APPLICATIONS:

- LIGHT CONTROL SYSTEMS
- ALARM SYSTEMS
- AIR CONDITIONING
- DATA ACQUISITION SYSTEMS
- ETC.

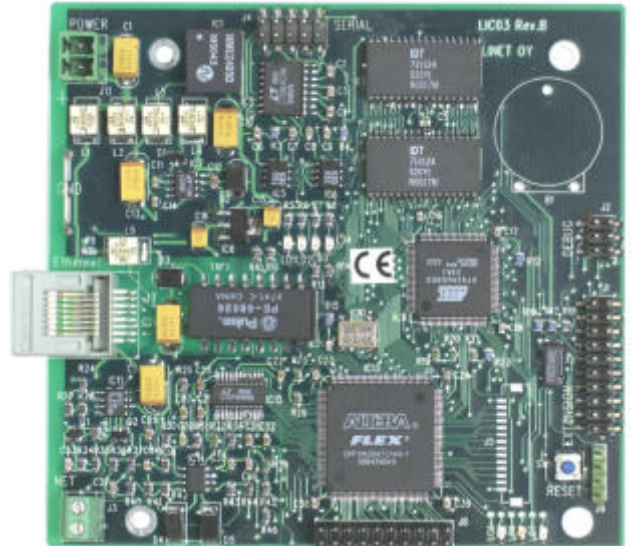

**PRELIMINARY**

### 1. DESCRIPTION

Linnet network controller is a stand-alone network power supply and controller to be used in the LINET 'Light Control Network' system. It contains a LINET bus driver, an onboard RISC microcontroller and firmware for running the standard network functions, an RS232/RS485 serial interface, an Ethernet interface for connection to industrial Ethernet or intranet systems, and an extension bus for a local microcomputer. The controller also contains a real-time clock for such stand-alone applications that require timing.

The maximum number of nodes in a LINET network is 200 pcs and the maximum total length of the network cable is 200 m. Networks can be connected together via the controllers to form a larger network.

LINET network uses time division protocol. All nodes have their own time slot in the signal frame. Each frame starts with a synchronization field, followed by system service bits. Next comes the 200 data bits, one for each node. The total frame length is 253 bits. During one frame each node can send and receive one bit of information. Each node can transmit and receive the full 80 bits/s all the time. The carrier frequency of the network is 20 kHz so the system full duplex data rate is about 200x80 bits/s. The nodes have always a constant system delay and constant data throughput rate.

LINET network uses twisted pair cable to minimize cost and electrical interference. This network carries both the bi-directional network data and the power needed for the nodes. The signal is basically sinusoidal to minimize EMI interference. Also, there is no need for bus termination and the user can use any network topology (bus, star, tree) to connect the nodes into the network. The interface of the nodes to the network is polarity free. This all minimizes the risk of false connections, which is the most common reason for network malfunctions.

**TABLE 1.ELECTRICAL SPECIFICATIONS**

PARAMETER	TYP.	UNITS
<b>Power supply</b> Supply voltage Average supply current, max. with 200 nodes	24 (± 5%) 1.0	Vdc Adc
<b>Linet bus connection</b> Supply voltage Supply current, max. (200 nodes) Power consumption, max. (200 nodes) Bus frequency, sine wave Number of nodes, maximum Length of network cabling, maximum	40 1.5 8 20 200 200	Vpp A (peak) W kHz pcs m.
<b>Serial interface</b> Standard interface Standard interface speed Standard interface settings (data, stop, parity) Selectable interface (option) Isolation	RS232 19200 8,1,N RS485 100	bits/s   Vdc
<b>Ethnernet interface</b> Network interface Network connector	10BASE-T RJ-45	

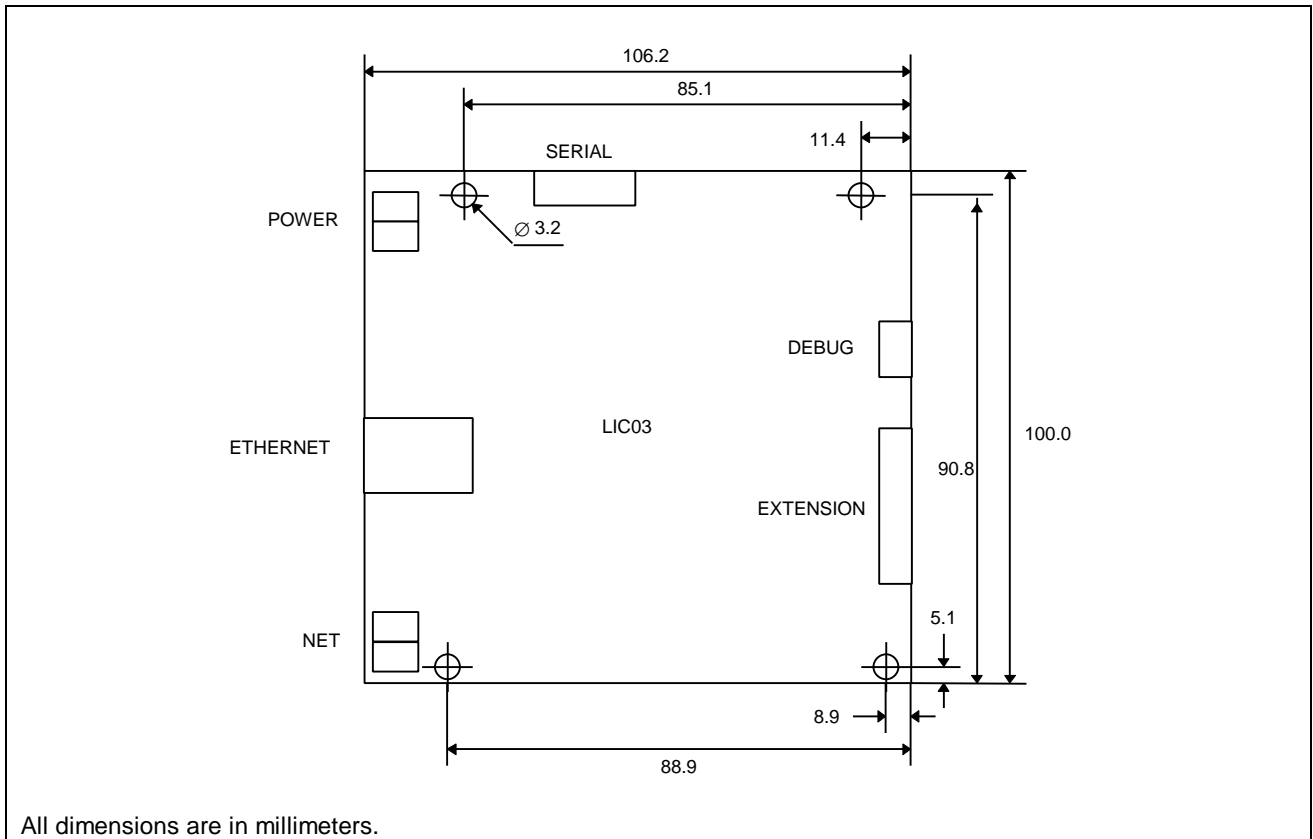

Figure 1. Outline dimensions and connectors.

**2. CONNECTIONS**

**2.1. POWER INPUT (J1)**

The connector J1 is power supply input. Power cables no larger than 1.0mm<sup>2</sup> will fit. Please pay attention to correct polarity when connecting. The input is protected by a zener diode across the input. False polarity on input will short circuit the power supply, and in the long run damage the controller.

## 2.2. LINET NETWORK CONNECTOR (J3)

Connector J7 is the Linet network connector. Any 2x0.5mm<sup>2</sup> unshielded twisted pair cable (such as Belden type 8205) can be used as a network cable. The Linet network is polarity and topology free. Any terminators are not needed. Maximum total length of the network cable is 200 m. The controller can locate anywhere in the network, but the most favorable location would be in the middle of the network so that the average distance between the nodes and the controller would be at its minimum.

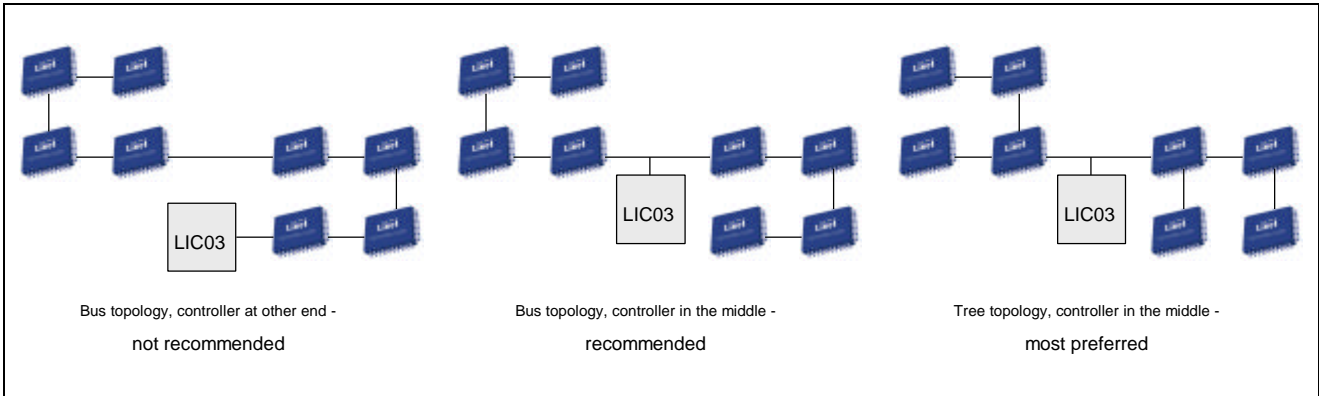

Figure 2. Network topology examples.

The network output is protected against short circuits. Never connect any foreign voltage source to the Linet network cable. Never connect the network cable to a conducting area such as enclosure or earthing etc.

## 2.3. RS232/485 SERIAL CONNECTOR (J4)

J5 is the RS232/485 serial line connector. The asynchronous serial port can be configured to use either RS485 buffering with RxD and TxD signals or RS232 buffering with partial hand-shaking through PC-standard 9-pin D-connector. The standard controller is equipped with RS232 buffering, so RS485-specific pins (7,8) are unconnected.

TABLE 2. RS232/485 SERIAL CONNECTOR

SYMBOL	NUMBER	TYPE	NAME AND FUNCTION
-	1	-	-
-	2	-	-
RxD	3	OUTPUT	EIA-232
RTS	4	OUTPUT	EIA-232
TxD	5	INPUT	EIA-232
CTS	6	INPUT	EIA-232
D-	7	IN/OUT	EIA-485 (option)
D+	8	IN/OUT	EIA-485 (option)
sGND	9	-	EIA-232/EIA-485 (isolated/un-isolated) signal ground
isol. +5V	10	-	isolated 5V output for EIA-485 termination

The serial interface is either isolated or un-isolated. Isolated interface is recommended when the controller is continuously connected to a host. Un-isolated interface can be selected when the host is connected only when the network is configured. Note that the isolation is to reduce noise, it is not intended to meet any isolation safety standards.

## 2.4. EXTENSION BUS (J1)

J2 is the controller's microprocessor bus extension connector. An optional user interface can be mounted to the extension port. The user interface consists of a LCD display with 8 softkeys. The display area consists of 20 characters in four rows. The interface can be either fixed or removeable. The interface hardware is documented in appendix 'D'.

**TABLE 3. EXTENSION BUS**

SYMBOL	NUMBER	TYPE	NAME AND FUNCTION
GND	1	-	-
GND	2	-	-
+5Vdc	3	OUTPUT	-
+5Vdc	4	OUTPUT	-
WR/	5	OUTPUT	Write signal
RD/	6	OUTPUT	Read signal
CS1/	7	OUTPUT	Chip select signal
CS2/	8	OUTPUT	Chip select signal
RESET/	9	OUTPUT	Reset signal
ALE	10	OUTPUT	Address latch enable signal
AD0	11	I/O	Address/data
AD1	12	I/O	Address/data
AD2	13	I/O	Address/data
AD3	14	I/O	Address/data
AD4	15	I/O	Address/data
AD5	16	I/O	Address/data
AD6	17	I/O	Address/data
AD7	18	I/O	Address/data
-	19	-	reserved
-	20	-	reserved

**2.5. THE ETHERNET CONNECTOR (J7)**

The controller may be connected to 10BASE-T ethernet networks via a standard RJ45 connector.

**3. NETWORK LENGTH**

The Linet network uses low frequency sine wave carrier, which transmits data and current to the nodes. The selected cable is a compromise between it's capacitance and resistance.

The maximum length of the network has been specified according to bus topology described in fig. 4. The total number of nodes has been divided into four clusters, which are then connected to the bus topology network between even longitudes. The resulting length can be seen in fig. 5.

The cable used in this specification is Belden type 8205, which is an unshielded single twisted pair cable, 2x0,5mm<sup>2</sup>.

Under special circumstances may the maximum cable length exceeded. E.g. when star topology is used, thinner cable may be selected and thus it's total length may exceed the specification. Please consult Linet for more information.

**4. EMC CONSIDERATIONS**

In a Linet network, majority of the noise is radiated from the controller. The source of the highest interference on the controller card is the clock crystal, which is located close to the center of the card. Wiring should be kept as far as possible from the crystal.

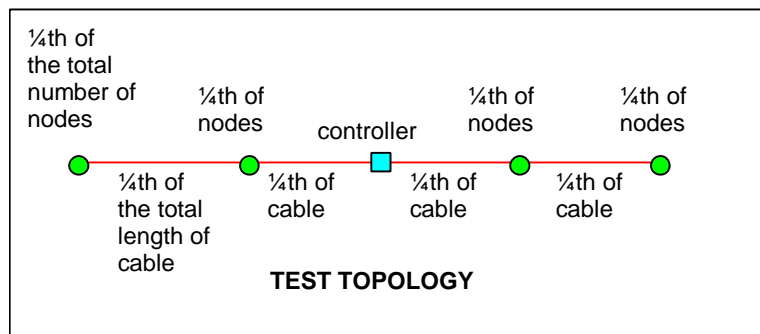

Figure 3. Topology to specify maximum network length.

**T.B.A.**

Figure 4. Maximum network length vs. quantity of nodes.

A metal enclosure is usually not essential. If such is used, it should be as small as possible and grounded to protective earth. Ungrounded enclosure has no positive effect on EMI. Additionally, wiring inside the enclosure should be kept as short as possible. Use of shielded wires inside the metal enclosure and ferrite rings close to the wire inlet will reduce EMI.

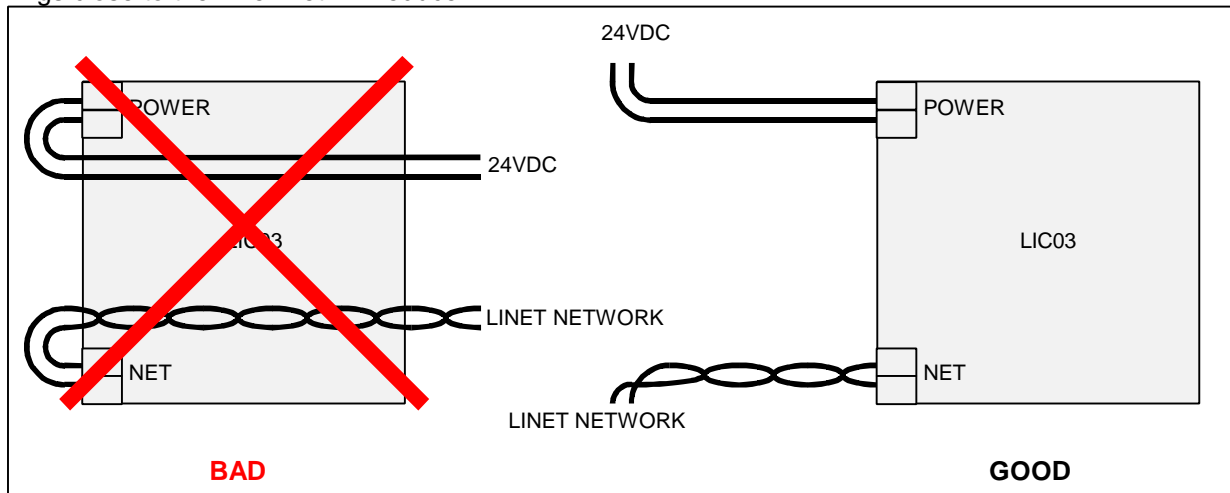

Figure 5. Wiring examples.

Capacitors across the power input and from the negative input to the protective earth will reduce EMC to the supply wires. The required capacitance depends on installation. Values from 1 $\mu$ F up to 6.8 $\mu$ F may be sufficient in most installations.

The controller fulfills the limits specified in the EMC standards EN50081-1 (for primarily residential use) and EN50081-2 (for primarily industrial use) without encasing. EMI level generated by an equipment incorporating a Linet controller is however dependent on comprehensive design of the equipment.

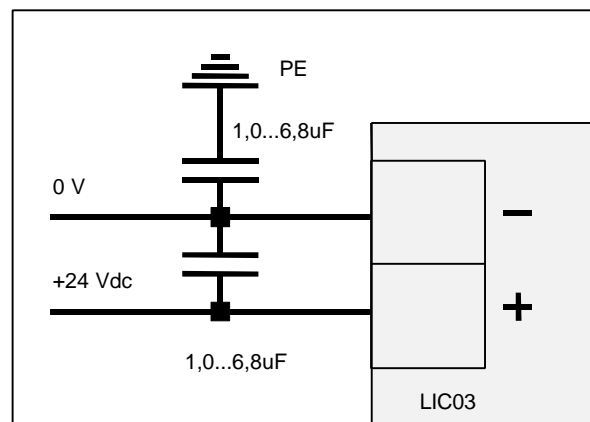

Figure 6. Power input filtering.

## 5. OTHER INFORMATION

It is not guaranteed that start-up or brown-out glitches doesn't occur on outputs of network nodes connected to a network controlled by a LIC03 controller. In applications where start-up glitches absolutely may not occur, the twisted pair cable network should be connected to the controller via a relay. The LIC03 controller includes a control output for this relay. Please consult Linet for details.

## 6. ORDERING INFORMATION

TABLE 4. PART NUMBERS AND DESCRIPTION

PART NUMBER	DESCRIPTION
LIC03-01	Linet network controller w. un-isolated serial interface RS232
LIC03-02	Linet network controller w. isolated serial interface RS232
LIC03-11	Linet network controller w. Ethernet interface, un-isolated serial interface RS-232
LIC03-12	Linet network controller w. Ethernet interface, isolated serial interface RS-232

Available by request: • RS485 version • custom features on the operating system • battery backup on system calendar and clock (add suffix B to the part number, e.g. LIC03-01B).

Linet products are not suitable for use as safety critical components (a) in life support devices, (b) in or on an aircraft, (c) in a nuclear plant, without the written approval of Linet Oy.

US pat. 5.920.253. Patented in the USA and Finland. Other patents pending. 'Linet' is a registered trademark. In the interest of product development, Linet Oy reserves the right to alter or improve the specification or design at any time without notice.

Copyright Linet Oy, 2001. Copying is permitted only when the material is unmodified and kept as a whole.

# APPENDIX A. CONNECTING USER INTERFACE

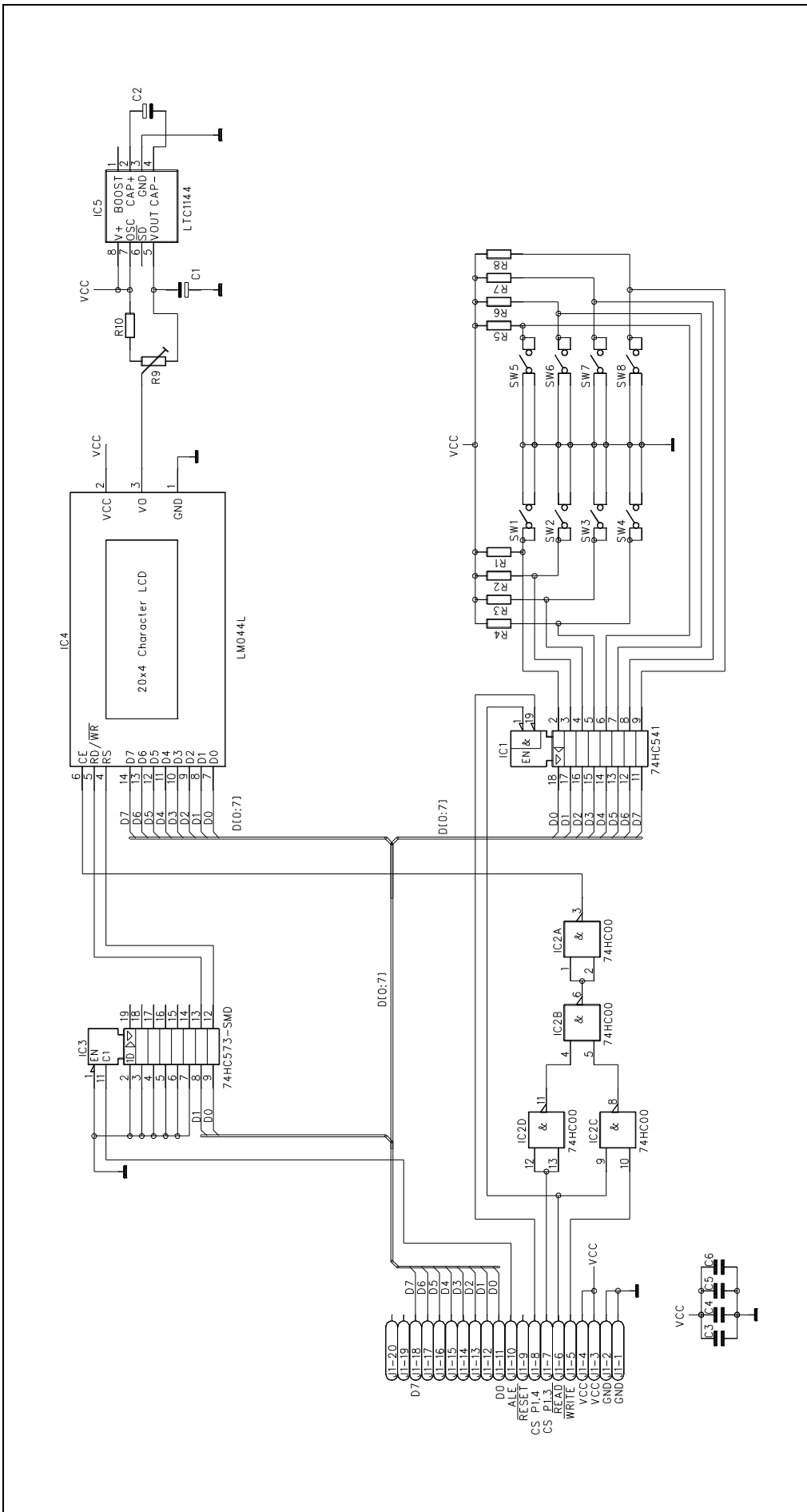

Figure 7. User interface schematics.

A design example on how to connect an user interface to the controller is presented in fig. 7. The connector J1 on the interface is connected to the extension connector on the LIC03 controller.

The standard user interface consists of 4x20 character LCD display and 8 pushbutton softkeys, which are typically arranged on the sides of the display. Pushbutton SW1 stands for 'OK'-function, SW8 for 'Cancel'-function. The other pushbuttons are 'softkeys' and their function is displayed on the corresponding text row on the display.

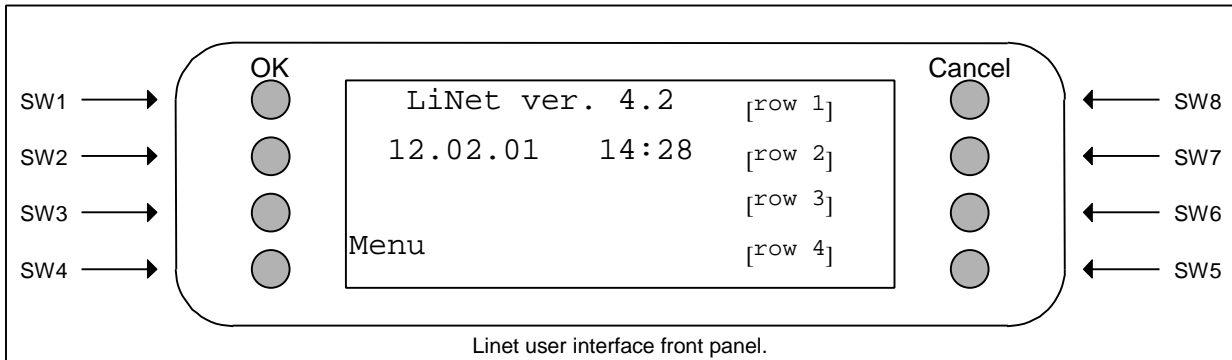

Figure 8. Suggested layout of the front panel.

## APPENDIX B. THE SERIAL CABLE BETWEEN THE CONTROLLER AND A PC

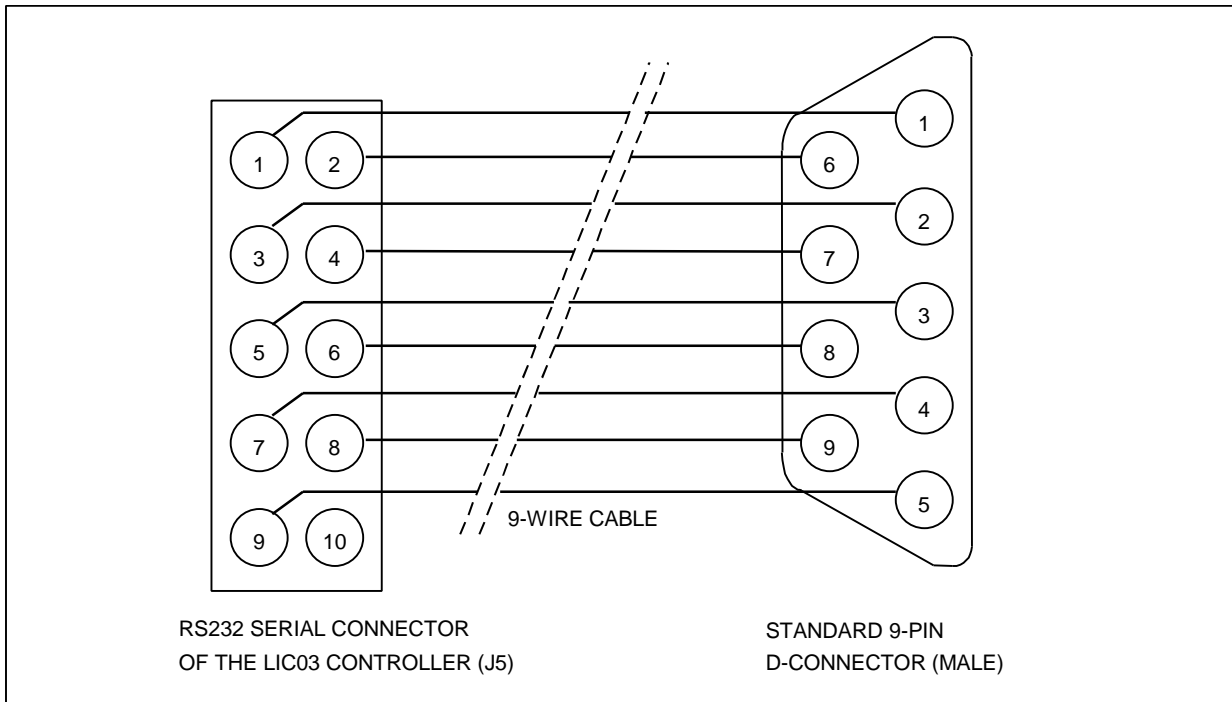

Figure 9. The serial cable.

When using the serial interface of the controller connect the controller to a PC, a cable as shown in figure 8 should be used in addition to a 'null modem' cable. J5 pins 1 and 2 are not in use, and pins 7 and 8 are for the optional RS485 interface. These pins may be unconnected.